

HK K C E-Motor 24V

DC 24V electric motor

HANSA FLEX

Properties

Design	Direct current motor for industrial applications
Voltage	24 V

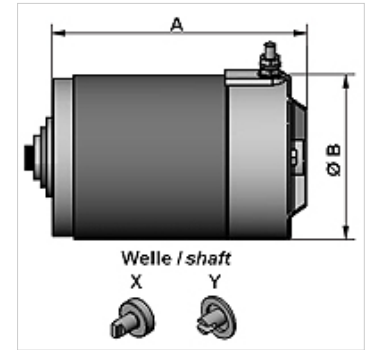

Item

Identification	A	Ø B	Design	Power	Direction of rotation	Speed max.	Cyclic duration S2 operation	Cyclic duration S3 operation	Protection class	Shaft	Weight
	(mm)	(mm)		(kW)		(rpm)	(min)	(%)			(kg)
HK KC 41	158,5	80,0	-	0,5	reversible	2800	5,0	17,0	IP54	type Y Ø15.6 x 6.5 x 10.5	2,60
HK KC 79	215,5	112,5	with fan	2,0	clockwise rotating	2200	4,5	10,0	IP23	type X Ø17.9 x 8.3 x 9.0	7,75
HK KC 92	173,5	114,0	-	2,2	clockwise rotating	2600	1,2	4,5	IP54	type X Ø17.9 x 8.3 x 9.0	6,90
HK KC 94	158,5	80,0	-	0,8	reversible	4000	2,5	8,0	IP54	type Y Ø15.6 x 6.5 x 10.5	2,60
HK KC 95	237,0	131,0	-	3,0	clockwise rotating	2600	4,0	15,0	IP54	type X Ø16.8 x 8.0 x 7.0	12,60
HK KC 97	183,0	114,0	-	2,0	clockwise rotating	2200	2,0	5,0	IP54	type X Ø17.9 x 8.3 x 9.0	7,16
HK KC 103	173,5	114,0	with thermal contact	2,2	clockwise rotating	2600	1,2	4,5	IP54	type X Ø17.9 x 8.3 x 9.0	6,70
HK KC 104	237,0	131,0	with thermal contact	3,0	clockwise rotating	2600	4,0	15,0	IP54	type X Ø16.8 x 8.0 x 7.0	12,50
HK KC 111	237,0	131,0	with fan	3,0	clockwise rotating	3300	6,0	20,0	IP12	type X Ø16.8 x 8.0 x 7.0	12,50

Accessories

HK K REL	Start relay for DC electric motor
HK K CAP	Cap for DC electric motors